



A CSW Industrials Company

TRUaire FV600 Series

Stamped Steel Foundation Vent

Model: _____ Size: _____

Project Information:

Job Name: _____

Location: _____

Engineer: _____

Submitted to: _____

For: Reference Approval Construction

Submitted by: _____

Reference: _____

Submittal Information:

Approval: _____

Date: _____

Construction: _____

Unit #: _____

Drawing #: _____

Construction Options

Bug Screen _____

Galvanized _____

Electro-Galvanized _____

(Sec. I) Features

- One Piece Construction
- 26 Gauge Sheet Metal

(Fig. I) Product Image:

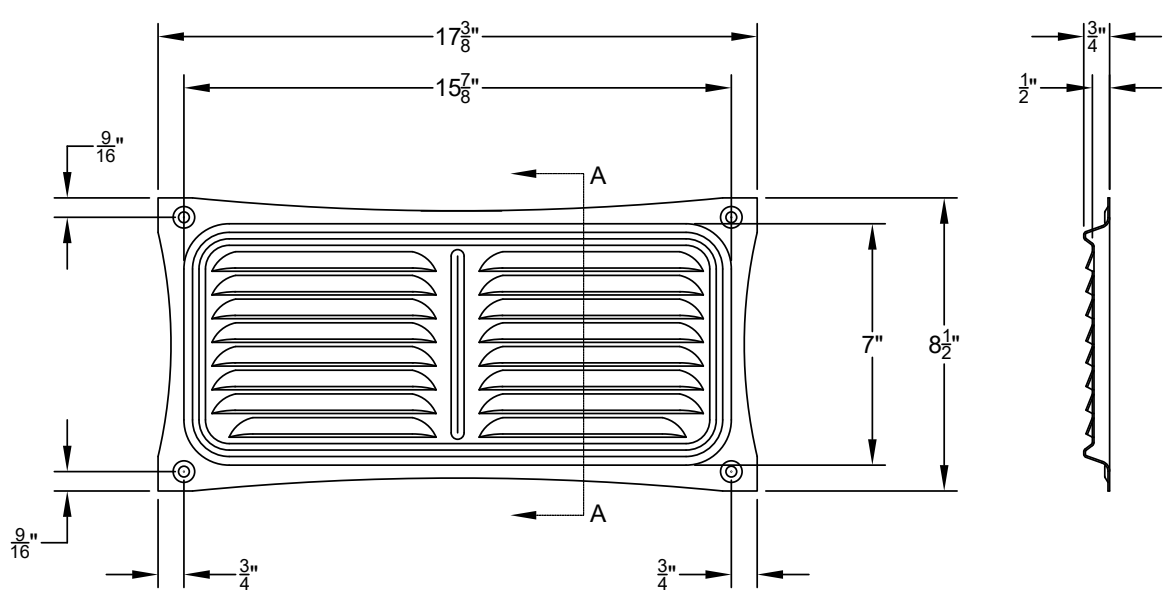

Note: This submittal is meant to demonstrate the general dimensions of this product. The illustrations are not meant to detail every aspect of the product. Drawings are not to scale.



RectorSeal® • 2601 Spenwick Drive • Houston, TX 77055 • 800-231-3345 • rectorseal.com

A CSW Industrials Company. RectorSeal, the logos and other trademarks are property of RectorSeal, LLC, its affiliates or its licensors and are protected by copyright, trademark and other intellectual property laws, and may not be used without permission. RectorSeal reserves the right to change specifications without prior notice. ©2022 RectorSeal. All rights reserved. R50956-0722