



A CSW Industrials Company

TRUaire 157M Series

Welded Steel Deluxe 1/2" Blade Spacing 2-Way Floor Register

Model: _____ Size: _____

Project Information:

Job Name: _____

Location: _____

Engineer: _____

Submitted to: _____

For: Reference Approval Construction

Submitted by: _____

Reference: _____

Submittal Information:

Approval: _____

Date: _____

Construction: _____

Unit #: _____

Drawing #: _____

Finish Options

Pristine White Powder Coat Finish

Textured Non-Scuff Brown Powder Coat Finish

(Sec. I) Features

- Heavy Duty Construction
- One Piece Frame
- Individually Welded blades
- SmoothGlide™ Multi-Shutter Damper
- Foot Operated Wheel Control

(Fig. I) Product Image:

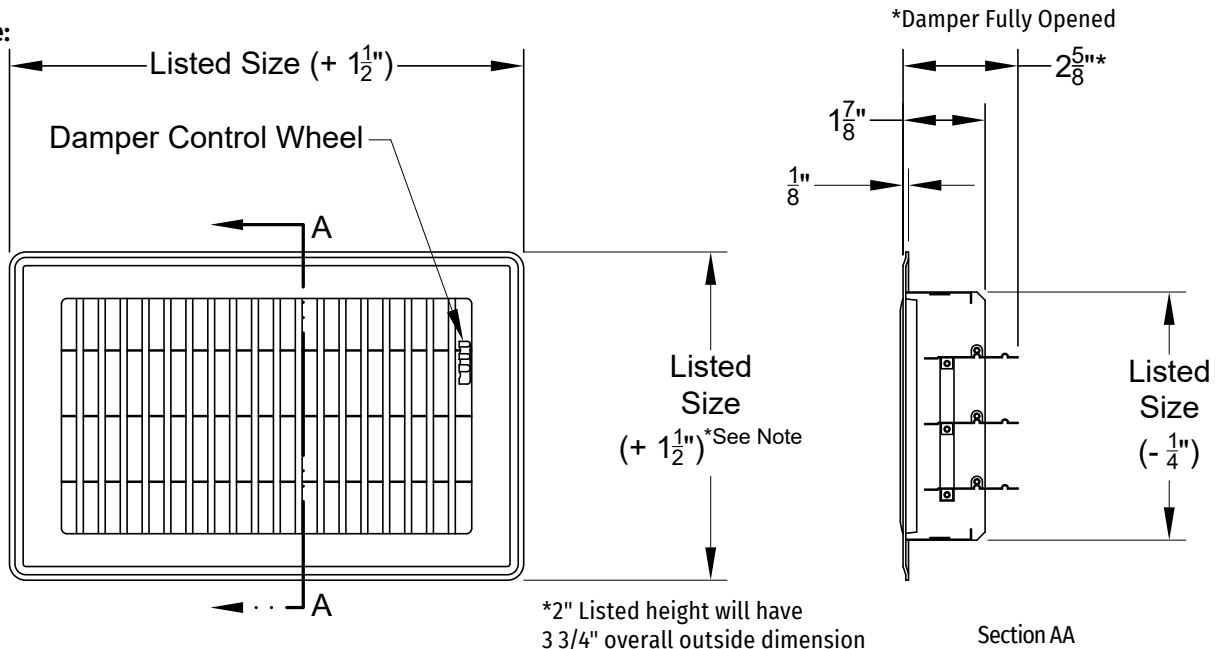

RectorSeal® • 2601 Spenwick Drive • Houston, TX 77055 • 800-231-3345 • rectorseal.com

A CSW Industrials Company. RectorSeal, the logos and other trademarks are property of RectorSeal, LLC, its affiliates or its licensors and are protected by copyright, trademark and other intellectual property laws, and may not be used without permission. RectorSeal reserves the right to change specifications without prior notice. ©2022 RectorSeal. All rights reserved. R50956-1022