



My hearing aid information

Product: ReSound Key

Model: 62

Serial number (R):

Serial number (L):

Battery size: 13



Quick guide

ReSound Key 62

Multi-function button (A):

MULTI-FUNCTION BUTTON ACTION	RESULT
Short press UP	
Short press DOWN	
Long press UP (3 seconds)	
Long press DOWN (3 seconds)	

Programs:

(if set up by your hearing care professional)

PROGRAM	WHEN TO USE	BEEPS
1		1
2		2
3		3
4		4

Get to know your hearing aids

1. Multi-function button
2. Microphone
3. Receiver
4. Dome
5. Battery door
6. Model and serial number (in battery chamber)
7. Receiver wire

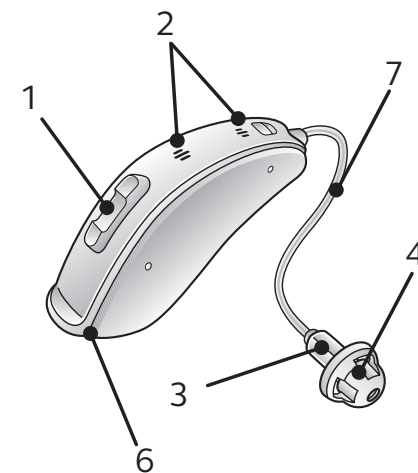

View ReSound hearing aid tutorial videos at youtube.com/resoundus.

What you need to know

Getting started: On/Off function

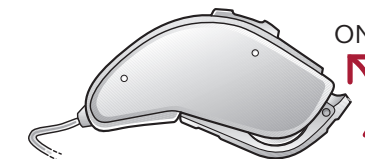

ON: Insert battery & completely close battery door (5). Program 1 will be active.

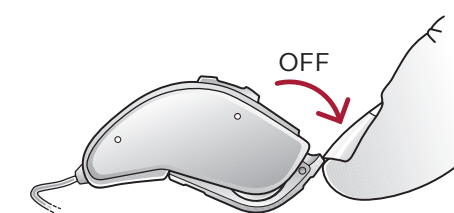

OFF: Open the battery door. Use fingertip to pull it all the way.

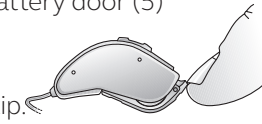

Inserting/Replacing the battery:

1. Open the battery door (5) completely by using your fingertip. 
2. Remove protective sticker from battery and wait two minutes before inserting the battery into the hearing aid to allow full activation of the battery. 
3. Insert the new battery with the positive side (flat side) in the correct position, as shown. 
4. Gently close the battery door. If it doesn't close easily, check to see if the battery is upside down.

Flight mode: (if enabled by your hearing care professional)

Some airlines prohibit the use of wireless hearing aids (RF transmitters) onboard. If required by your airline, enable flight mode:

Disable wireless operation by opening and closing the battery door three times within ten seconds (open-close, open-close, open-close). Your instruments will now be in flight mode.

The hearing aids must function in flight mode for ten seconds before wireless operation can be re-enabled.

To re-enable wireless operation, open and close the battery door one time and wait thirty seconds before opening the battery door again to avoid accidentally entering flight mode again.

For more information

Refer to the user guide included in your hearing aid box.

Your hearing care professional can be reached at:

View ReSound hearing aid tutorial videos at [youtube.com/resoundus](https://www.youtube.com/resoundus).

Manufacturer according to FDA:

GN ReSound North America
8001 E Bloomington Freeway
Bloomington, MN 55420
USA
1.888.735.4327
[resound.com](https://www.resound.com)



401615011 Rev A 2020.11

Regular care & maintenance

Daily: Clean your hearing aid.

Keep your hearing aids dry. Clean the hearing aids using a soft cloth or tissue.

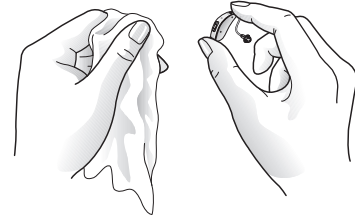

Weekly: Clean the receiver tubes and domes (4).

Use a soft cloth to clean the receiver tube and dome on the outside. Do not use water when you are cleaning the receiver tubes.

As needed: Change domes (4)

ReSound standard domes

1. Push the new dome over the receiver.
2. Make sure that the new dome is properly and securely maintained.



ReSound tulip domes

Tulip domes consist of two “petals”. It is important that the largest petal is the outermost petal. To ensure this:

1. Push the largest petal away from the receiver tube using a finger. This bends the petal forward.
2. Then push the largest “petal” back, and it will be placed on top of the smaller petal.

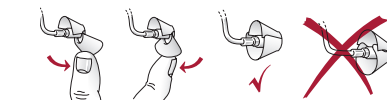

Monthly: Change the wax guard or see your hearing care professional.

For changing white wax guards, complete the following steps:

1. **Removal:** Insert the removal side of the wax guard tool into the used wax guard so that the shaft of the tool is touching the rim of the wax guard. Slowly pull the wax guard straight out.

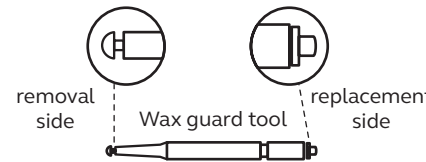

2. **Insertion:** To insert the new wax guard, gently press the replacement side of the wax guard tool straight into the hole of the sound outlet until the outer ring lies flush with the outside of the receiver. Pull the tool straight out. The new wax guard will remain in place.

Beep/tone indicators

BEEP/TONE	INDICATION	ACTION REQUIRED
Ding, ding, ding, dong	Low battery	Change battery
Ding (5 or 10)	Hearing aid is starting up	After dings cease, hearing aid is turned on
Ding-ding, ding-ding, etc.	Hearing aid is in flight mode	Use in flight mode if desired, or open-close battery door to exit flight mode
Ripple tone	Hearing aid is in streaming mode	Use with wireless accessory or press multi-function button to exit streaming mode

View ReSound hearing aid tutorial videos at [youtube.com/resoundus](https://www.youtube.com/resoundus).

Troubleshooting

SYMPTOM	CAUSE	POSSIBLE REMEDY
No sound	Battery door not closed Dead battery Battery door will not close Blocked earmold Blocked wax guard	Turn on by closing the battery door (5) Replace battery Insert battery properly Clean earmold Replace wax guard or consult your hearing care professional
Not loud enough	Blocked earmold or dome Change in hearing, volume too low Excessive ear wax	Clean earmold, replace dome, replace guard Consult your hearing care professional Clean the dome (4)/consult your hearing care professional
Excessive whistling/feedback	Incorrect earmold placement Incorrect dome placement Excessive ear wax If none of the above	Re-insert earmold carefully Re-insert dome (4) Clean the dome (4)/consult your hearing care professional
Wireless does not work	Device may be in flight mode	Open and close the battery door (5) once. Wireless operation will reactivate ten seconds later.

If there are any other problems not mentioned in this guide, please contact ReSound or your hearing care professional.