

BBB

BOTTOMFIT BOTTOM BRACKET

BBB CYCLING®
ROOSEVELTSTRAAT 46, 2321 BM LEIDEN
THE NETHERLANDS

BBBCYCLING.COM

EN Manual	HU Használati utasítás
DE Handbuch	PL Podręcznik
FR Manuel	CZ Uživatelská příručka
NL Handleiding	JP 使用説明書
ES Manual	RU Руководство пользователя
PT Manual	SK Manuál
IT Manuale	NO Håndbok

BBO-71/81

COMPONENTS:

- ① Bottom bracket shell
- ② Non-drive side cup (x1)
- ③ Drive side cup (x1)
- ④ ShimSet spacers
- ⑤ Wave spring washer

● Included ● Not Included

COMPATIBILITY

BBO-71:

- PF30 (68 x Ø46mm) + Ø24mm spindle Road cranksets

BBO-81:

- BB30 (68 x Ø42mm) + Ø24mm spindle Road cranks

RECOMMENDED TOOLS

- BTL-27L BracketGrip x2
- Grease
- Torque wrench
- PTFE (Carbon BB shell)
- Caliper or ruler
- Anti-seize (Ti BB shell)

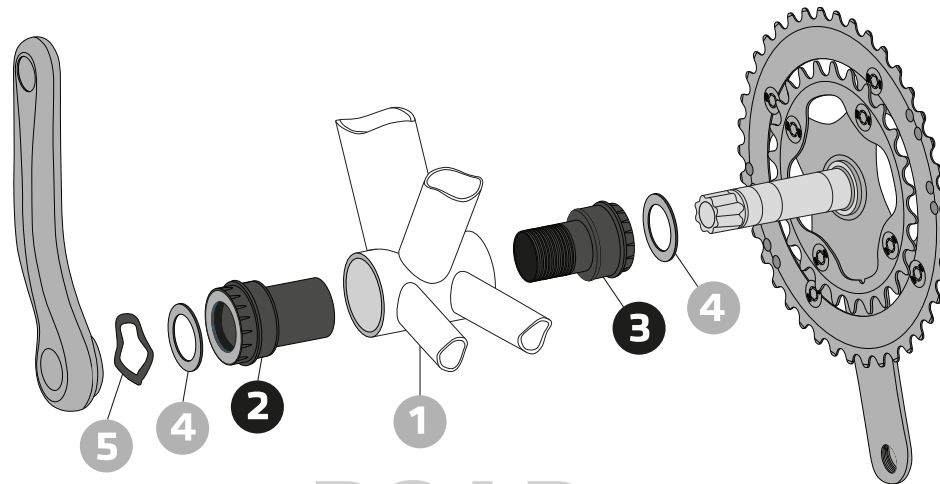

IMPORTANT:

- * Before installing a bottom bracket, use a reaming tool to ensure the bottom bracket (BB) shell ① is clean and free of metal chips, dirt and excess paint.
- * Inspect the BB shell for width, ID, ovalization or anything that could cause bearing mis-alignment.
- * Always use a calibrated torque wrench to tighten crank bolts.
- * BBB Cycling cannot guarantee compatibility with you frame and/or crank combination, consult your manufacturer for compatibility.
- * BBB Cycling cannot be held responsible for any damage occurred.

Find your translation
on BBBcycling.com



WARNING

Sold only by professional bicycle dealers.
For proper installation, ask your BBB dealer.
Not following the instructions in this manual may cause damage to the product not covered under warranty, damage to the bicycle, or cause an accident resulting in injury or death.

INSTALLATION

1. After checking BB shell ① carefully, apply a thin layer of grease, PTFE (for Carbon) or anti-seize compound (for Ti) on the inside surface of BB shell ①.
2. Apply a little bit of grease on the drive side cup thread. DO NOT use PTFE, anti-seize or thread locking compound.
3. First insert the non-drive side cup ② by hand then insert drive side cup ③ until the threads engage while making sure you do not cross-threads the cups.
4. Use the BracketGrip cup tools to tighten until the lip of the cups are flush against the BB shell ① (Max. 40Nm).
6. Install crankset following manufacturers specifications.
7. Add ShimSet spacers ④ as necessary to take up any play or adjust chainline. If binding occurs or the crankset gets loose over time, try removing spacers or use a Wave spring washer ⑤ (instead of spacers) to add preload on the bearings and crankset.

